

CNC TOOLING PARAMETERS

X24-16 PROFILE 80Ø 22MM BORE - 20MM SLAB

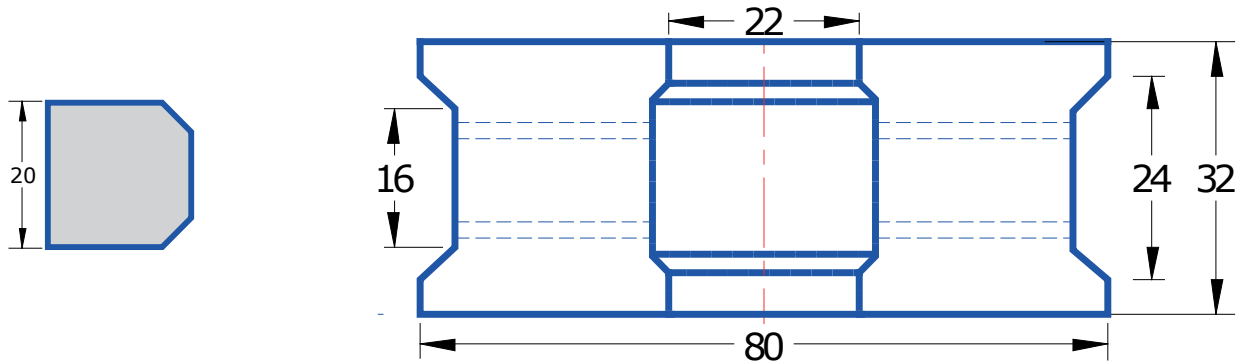

CODES AND POSITIONS

Pos	Description	Vetro Code	
Pos 1	Diamond H/S Iron	X24-16 Profile Pos 1 80Ø 22bore Seg	ST-0080
Pos 2	Diamond H/S Iron	X24-16 Profile Pos 2 80Ø 22bore	ST-0081
Pos 3	Diamond H/S Iron	X24-16 Profile Pos 3 80Ø 22bore	ST-0082
Pos 4	Diamond H/S Iron	X24-16 Profile Pos 4 80Ø 22bore	ST-0083
Pos 5	Rubber Polish Wheel	X24-16 Profile Pos 5 D1-60 22bore A Class	RP-0058
Pos 6	Rubber Polish Wheel	X24-16 Profile Pos 6 D1-60 22bore A Class	RP-0059
Pos 7	Rubber Polish Wheel	X24-16 Profile Pos 7 D1-60 22bore A Class	RP-0060

PARAMETERS

Pos	Type	RPM	Feed (m/min)	Removal (mm)
Pos 1	Segmented	6000	2-2.5	2max
Pos 2	Continuous	6500	3-3.5	0.4
Pos 3	Continuous	6500	3-3.5	0.2
Pos 4	Continuous	6500	2-2.5	0.1
Pos 5	Rubber	2500	0.8-1.2	0.05
Pos 6	Rubber	2500	0.8-1.2	0.03
Pos 7	Rubber	2500	0.8-1.2	0.02

CALL US ON 01268 766807

or visit our website www.vetrotooling.com
email us sales@vetrotooling.com