

CNC TOOLING PARAMETERS

TP33 PROFILE 120Ø 35MM BORE - 30MM SLAB

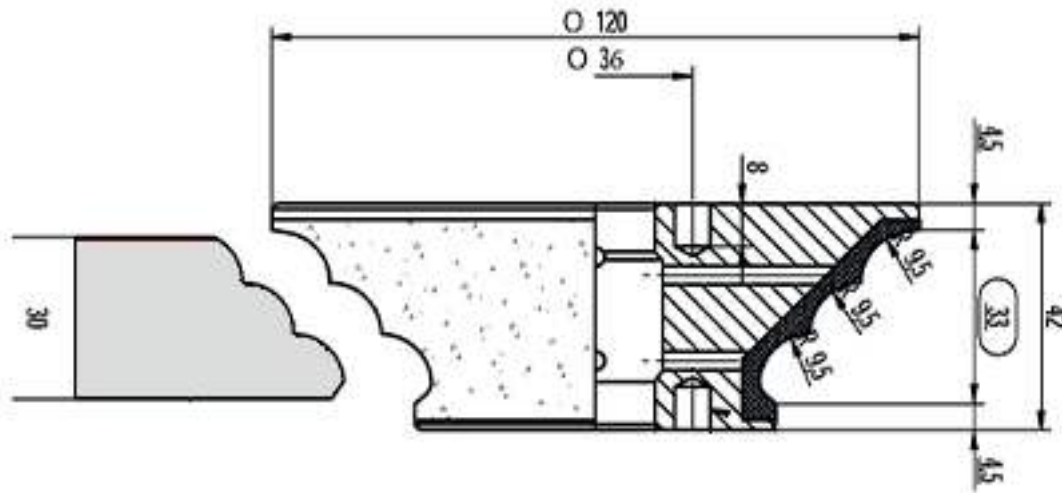

CODES AND POSITIONS

Pos	Description	Vetro Code
Pos 1 Diamond H/S Iron	TP33 Profile 120Ø 35bore Pos 1 Seg	ST-0217
Pos 2 Diamond H/S Iron	TP33 Profile 120Ø 35bore Pos 2	ST-0218
Pos 3 Diamond H/S Iron	TP33 Profile 120Ø 35bore Pos 3	ST-0219
Pos 4 Diamond H/S Iron	TP33 Profile 120Ø 35bore Pos 4	ST-0220
Pos 5 Rubber Polish Wheel	TP33 Profile 120Ø 35bore D1-60 Pos 5 A Class	RP-0147
Pos 6 Rubber Polish Wheel	TP33 Profile 120Ø 35bore D1-60 Pos 6 A Class	RP-0148
Pos 7 Rubber Polish Wheel	TP33 Profile 120Ø 35bore D1-60 Pos 7 A Class	RP-0149

PARAMETERS

Pos	Type	RPM	Feed (m/min)	Removal (mm)
Pos 1	Segmented	5500	3-3.5	2max
Pos 2	Continuous	6000	6-6.5	0.4
Pos 3	Continuous	6000	6-6.5	0.2
Pos 4	Continuous	6000	3-3.5	0.1
Pos 5	Rubber	2500	0.8-1.2	0.05
Pos 6	Rubber	2500	0.8-1.2	0.03
Pos 7	Rubber	2500	0.8-1.2	0.02

CALL US ON 01268 766807

or visit our website www.vetrotooling.com
email us sales@vetrotooling.com